

EV connection – implant abutment leakage testing: An In Vitro study

Stefan Johnsson, Anders Halldin, Magnus Holmquist
Dentsply Sirona, Mölndal, Sweden

Abstract

This study confirms the benefit of the inherent sealing capacity of a conical implant-abutment interface. The study utilizes a specific testing apparatus that uses an under-pressure inside the implant-abutment interface. This under-pressure together with cyclic loading of the implant abutment assembly allows possible leakage to be detected.

The study shows that EV connection with an internal conical seal design, has 4.5 times better sealing capacity compared to a flat-to-flat connection design.

Background and aim

Leakage of microbial content through the implant-abutment junction has been discussed as a factor contributing to inflammatory reactions in the adjacent tissue. When further updating and improving the implant-abutment connection, the assurance of a tight seal of this interface is an important aspect for the clinical outcome. The aim of this study was to detect possible fluid leakage of EV connection compared to a flat-to-flat implant-abutment connection.

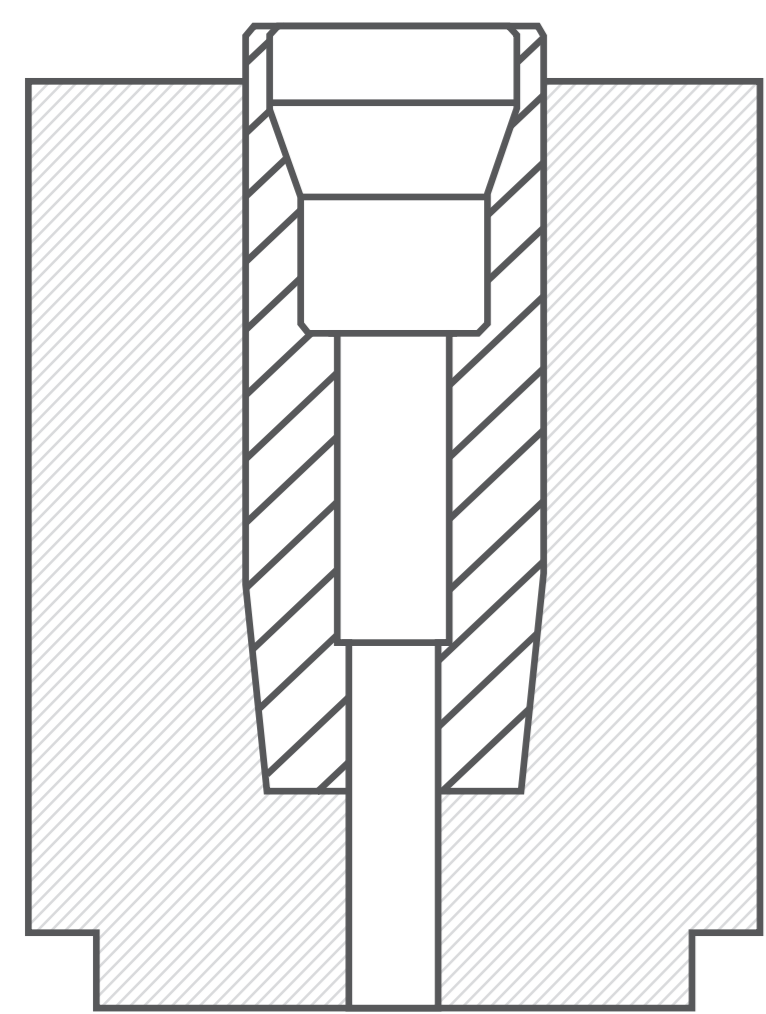

Figure 1. Implant modified for leakage testing via a circular hole drilled through the bottom of the implant.

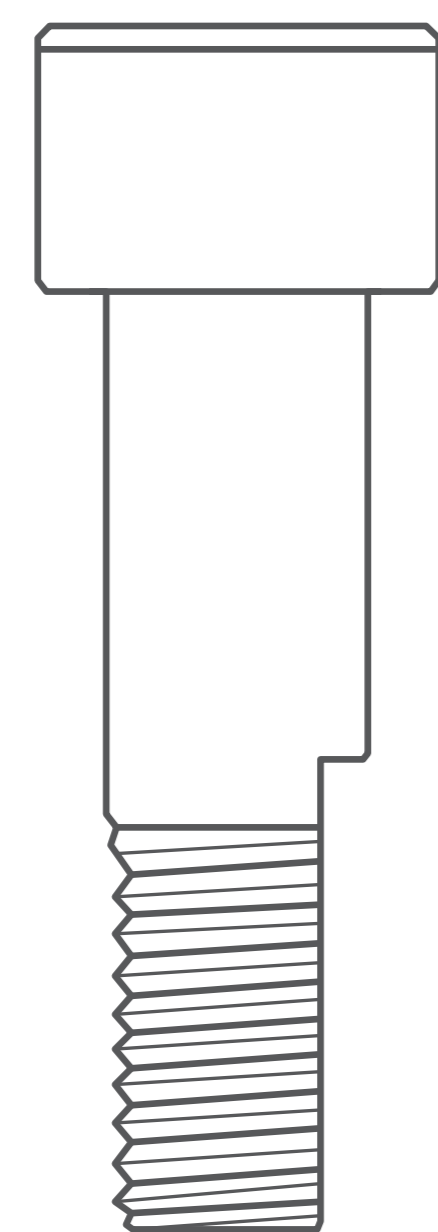

Figure 2. Abutment screw modified with a groove.

Methods and materials

To study the possible leakage through a conical seal interface a narrow hole was drilled at the bottom of the implant, see figure 1. A groove, parallel with the long axis of the abutment screw, see figure 2, was made on the threads of the abutment before mounting the implant-abutment specimen. Two-part abutments (TiDesign EV) were secured with 25 Ncm to the implants (OmniTaper EV Ø3.8 (M) L11mm, Dentsply Sirona, Mölndal, Sweden).

The fluid leakage test was performed under cyclic loading in accordance with the standardized method ISO 14801:2007. The upper section of the specimens (i.e. the conical seal design part), was submerged in a container with physiological sodium chloride solution at room temperature, while loading occurred simultaneously, see figure 3.

The lower section of the specimen engaging the apex of the implant (with the hole) was subjected to pressure (-0.30 bars) and subsequently connected to a fluid level measurement pipe. Fluid leakage was evaluated by continuously (over a period of 10 minutes) measuring the fluid level in the measurement pipe, giving a volumetric flow rate ($Q = \text{volume}/\text{time}$) at each load level. Possible leakage was evaluated from 3 specimens.

A control implant Xive S (D 3.8, L 11mm, Dentsply Sirona, Mölndal, Sweden) with corresponding Esthetic Base straight abutment tightened to 24 Ncm, was similarly tested for fluid leakage.

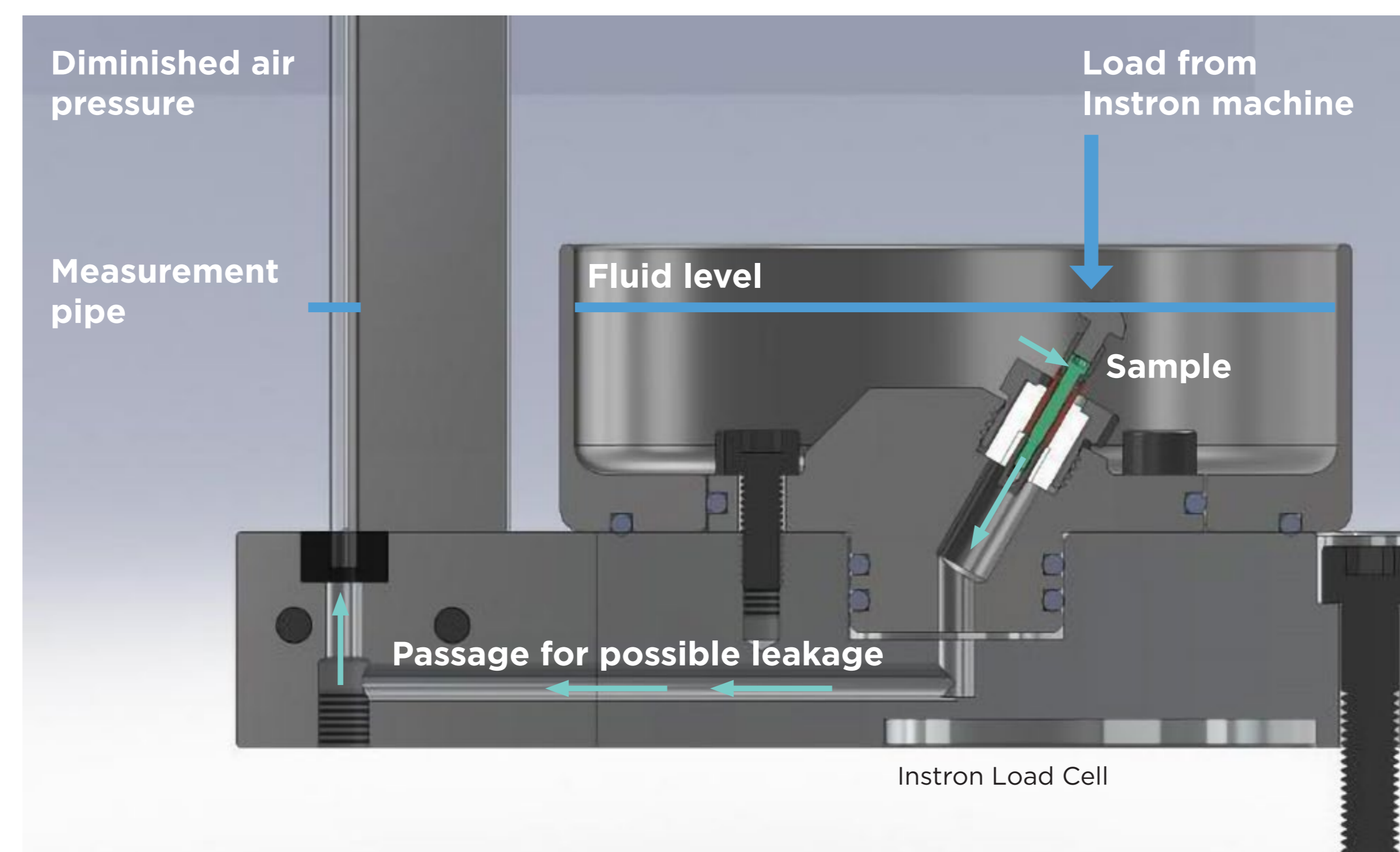

Figure 3. A schematic illustration of the test concept. The blue arrows show the possible leakage passage. Two different seals are used to prevent leakage; an O-ring underneath the sample and a wax plug inside the abutment. This prevents fluid leakage around the sample and also via the hollow of the abutment where the screw head is located. The only possible passage is through the connection between the implant and the abutment.

Results

No fluid leakage was detected for the implant-abutment system with EV connection during the 10 minutes test period, even at loads 4.5 times higher compared to the maximum load where the flat-to-flat implant-abutment showed no leakage, see figure 4.

EV connection was 4.5 times better in sealing capacity compared with the Xive S control system [2].

Conclusions

This study shows that the EV connection has 4.5 times better sealing capacity compared to the flat-to-flat connection design. The results showing minimized leakage agrees with previously published data presented for OsseoSpeed EV connection (Dentsply Sirona Implants) showing no leakage utilizing the same test apparatus [1].

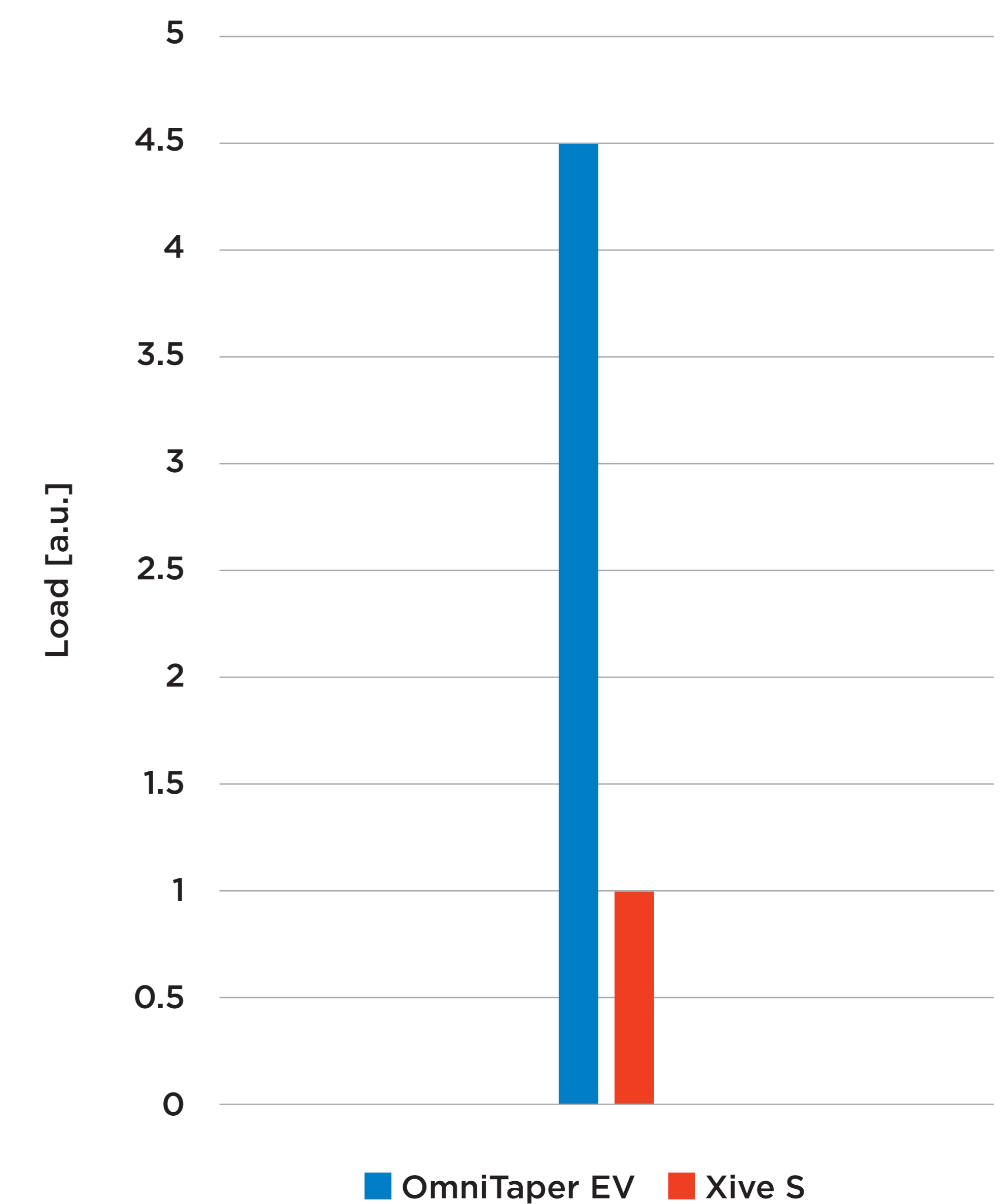

Figure 4. OmniTaper EV conical connection shows no leakage at loads 4.5 times higher compared to flat-to-flat connection Xive S [2].

References

- [1] Johansson H, Hellqvist J, Johansson S. Credibility of an up-dated implant system: implant abutment leakage testing (P340). Clin Oral Implants Res 2013;24((Supplement 9)):166-67
- [2] Johnsson S, Halldin A, Holmquist M. EV connection – implant abutment leakage testing. Data on file. Dentsply Sirona, Mölndal, Sweden